

Vacuum-Cooking-Cutter K 204



Vacuum-Cooking-Cutter K 204

The Seydelmann Vacuum-/Cooking-Cutter K 204 offers maximum ease of operation developed according to ergonomical requirements including an extensive equipment. The components of all Seydelmann Machines comply with the up-to-date technical development and contribute to an increase in product quality.

Facts

Bowl content:	200 Liters
Weight:	4100 kg / 9039 lbs
Loading options:	BW 120, BW 200
Power of motor:	
ultra v:	90 kW / 121 HP
ultra vs:	105 kW / 141 HP
AC-8:	100 kW / 134 HP

Machine design

The machine frame of the K 204 is almost entirely made of solid stainless steel. All edges are rounded and all surfaces are polished very precisely and designed with a slope enabling cleaning water to drain completely from all surfaces. The embedded covers and the closed bottom with ventilation prevent pollution and water from entering the machine. The knife hood is flow dynamically shaped. Hardly any unchopped product residue is left in the cover. The gap between the knives and the cover or the bowl is very small.

Applications

Besides the production of boiled-, dry- and cooked sausage, the universally applicable machine is suitable in particular for the chopping, mixing and emulsification of fresh meat, pre-cut frozen meat, cooked meat, fish, vegetables, meat substitute products made from plant-based proteins, fruits, confectionary goods and other edibles at temperatures from -12 °C (10 °F) up to 85 °C (185 °F).

Vacuum-Function

Cutting under vacuum, a firm emulsion free of air with a volume reduction of 5-7% is produced. Therefore, an even better fineness of the product is achieved. Thanks to the exclusion of air, the final product gains a significantly longer shelf life. A better protein extraction increases the moisture and fat absorption of the product improving the development of the flavour of spices next to the better binding and stability of the final product.

Cooking-Function

The bowl is heated up by hot steam from a nozzle system installed below the bowl. Enormous time savings can be achieved thanks to cooking and cutting in one step. The production time can be further reduced using an additional heating for the knife hood. An increase of approximately 10% in the volume of the material as well as the complete preservation of taste, aroma and protein is possible. Cooling is optionally available via a nozzle system.



Maschinenfabrik Seydelmann KG

info@seydelmann.com Tel. +49 (0)711 / 49 00 90-0 Hoelderlinstrasse 9
www.seydelmann.com Fax +49 (0)711 / 49 00 90-90 70174 Stuttgart, Germany

Cutters · Mixers · Grinders
Emulsifiers · Production Lines

Measurements

- H1 = 930 mm / 36.6 in
- H2 = 2610 mm / 102.8 in
- H3 = 2800 mm / 100.2 in
- T1 = 1760 mm / 69.3 in
- T2 = 2180 mm / 85.8 in
- B1 = 2100 mm / 82.7 in
- B4 = 3300 mm / 129.9 in
- X = 1820 mm / 71.6 in

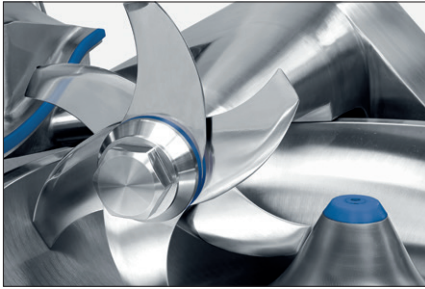
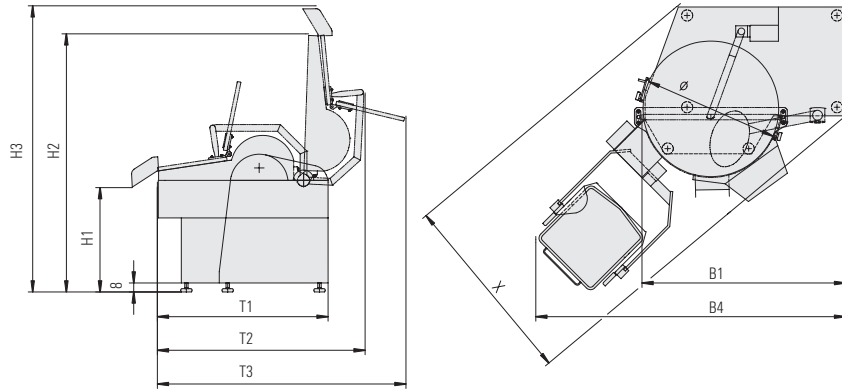

Knife head



Temperature sensor



Auto-Command 4000 (optional)

Standard equipment

- Vacuum- and/or Cooking-Function
- Operation via cross lever switches
- Changeable and balanceable knife head
- Hydraulic main cover, absorbing cover and ejector
- See-through noise absorbing cover made of special plastic
- Separate electrical cabinet made of stainless steel with integrated main switch
- Pneumatic locking of knife shaft arm
- Switch-off for temperature and operating time
- Temperature sensor
- Noise insulation
- Greasing point

Additional equipment

- Hydraulic loading device
- Control of unbalanced state
- Cable duct
- Various knife systems
- Frequency controlled stepless bowl
- Up to 9 switch-offs for temperature and operating time
- Variable adjustment of knife speed (only with AC-motor)
- Water nozzles with water meter
- Liquids dosing system with nozzle
- Direct steam
- Nitrogen input for gas flushing
- Liquid Nitrogen (LN₂) or carbon dioxide (CO₂) input for cooling
- Cover heating / -cooling
- Ejector with variable speeds
- Lock of noise absorbing cover
- Cover damping for noise absorbing cover
- Noise insulation version

Control: Auto-Command 1000

- 21,5" touch wide-screen LED color display
- Stainless steel housing
- Computer based automatic control
- Display of all technical parameters
- Program control
- 30 programs with up to 10 steps each
- Switching off or on when reaching up to 9 pre-programmable temperature or time values
- User-friendly logical design
- Display of maintenance and service intervals

Optional Auto-Command 2000, 3000, 4000

- 24.0" touch wide-screen LED color display
- Waterproof design IP 69
- Advanced recipe control with display of required ingredients and recipes
- User management
- Data recording
- Production plan
- Second workstation outside the production room possible
- Connection to MES or ERP systems possible

Motor types

AC-8

- 6 steplessly programmable knife speeds
- 2 reverse mixing speeds
- 2 separate bowl speeds
- Frequency-controlled 3-phase motor

Ultra

- 2 knife speeds
- 2 forward mixing speeds
- On request: 2 reverse mixing speeds
- 2 separate bowl speeds
- All drive systems with 3-phase motors