

Mixing Grinder MD 114



Mixing Grinder MD 114

The Seydelmann High Efficiency Grinder is a powerful and robust machine, that meets the highest quality demands of the end product under optimal hygienic conditions.

Facts

Hole plate diameter:	114 mm
Hourly output:	1000 kg/h 2205 lbs/h
Power of motor:	7/9 kW / 9/12 HP
Hopper content:	75 Liters
Mixing capacity:	50 kg / 110 lbs
Weight:	580 kg / 1279 lbs

Machine design

The machine has a closed machine frame. Therefore all technical parts are integrated in the machine. Motors are insulated against humidity and totally closed. The waterproof panel box is built into the machine. All surfaces are rounded, polished with high precision and designed with a slope, so that water can drain easily. Embedded covers in the stainless steel machine frame and the closed bottom prevent water from entering the machine or dirt from sticking to the openings. The worm housing, the worm as well as the union nut or bayonet locking are also made of solid stainless steel. The worm housing is also equipped with a trapezoidal thread which endures the toughest use on a long-term basis.

Applications

Specially suitable for grinding fresh, frozen and cooked meat as well as liver, spinach and other food products.

System

Thanks to the 2-speed working worm and the short time reverse gear of the MD 114, fresh meat and slightly frozen meat as well as cooked products, liver, spinach, etc. can be processed. The mixing unit is equipped with two strong arms or, optionally, paddles. The mixing arms mix the material evenly before grinding. The safety guard with switch-off contact makes it impossible to place a hand into the running mixing unit. The result of the fast and powerful grinding of the machine is a clear cut-image and a very high throughput for each hole plate size and each material. To improve the quality of the final product, a separating set is available as an optional equipment.



Measurements

- H1 = 430 mm / 17.0 in
- H2 = 1100 mm / 43.3 in
- H3 = 1160 mm / 45.7 in
- H4 = 50 mm / 2.0 in
- T1 = 850 mm / 33.5 in
- T3 = 1060 mm / 41.7 in
- B1 = 800 mm / 31.5 in

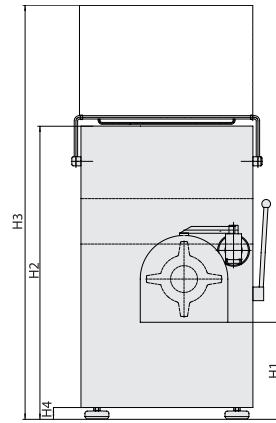
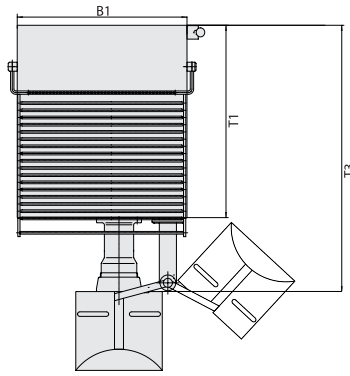

Top view: Hopper



Control panel



Bayonet locking (optional)

Standard equipment

- Two-speed working worm with manual switch
- Mixing unit with mixing arms
- Locking nut
- Worm ejector
- Standard cutting set
- Embedded covers
- Thermal overload control

Additional equipment

- Mixing unit with mixing paddles
- Bayonet locking
- Outlet protection device
- Outside knife
- Separating set
- Pneumatic separating device
- Extended feet for raised outlet height for BW 200
- Machine with wheels
- Lifting device



Outlet protection device (optional)



Outside knife (optional)



Separating set (optional)