

Automatic Mixer-Grinder AMR 1800



Automatic Mixer-Grinder AMR 1800 with cooling function, hydraulic hopper lid and snow horns

Automatic Mixer-Grinder AMR 1800

The Seydelmann Automatic Mixer-Grinders are designed for high throughputs. They are equipped with a long feeding worm in the middle of the mixing shafts, which is positioned in the bottom of the hopper parallel above the working worm. Therefore, fast emptying through the grinder outlet is guaranteed.

Facts

| | |
|------------------------------|---------------------------------|
| Hole plate diameter: | 200/250 mm |
| Mixing capacity: | 400-1000 kg 882-2005 lbs |
| Power of grinder motor: | max. 45/90 kW max. 60/121 HP |
| Power of AC-4 grinder motor: | max. 100 kW max. 134 HP |
| Power of mixing motor: | 6,5/8 kW / 9/11 HP |
| Hopper content: | 1800 Liters |
| Weight: | 4100 kg / 9039 lbs |
| Weight with loading device: | 4400 kg / 9700 lbs |

Machine design

The machine frame of the AMR 1800 is double-walled. Therefore all pipes, cables, cylinders and other parts are integrated into the machine. All edges are rounded and all machine surfaces are polished very precisely and designed with a slope allowing cleaning water to drain completely. Thanks to embedded covers and the closed bottom of the machine frame made of stainless steel, water cannot enter the machine and pollution is prevented.

Applications

For high throughputs of ground meat, hamburger, breakfast and dry sausage production as well as production of vegetables, fillings, etc.

System

The two mixing shafts with separate motors are independently switchable forward and reverse, at high and low speed. As standard the mixing shafts are equipped with paddles, enabling a fast emptying. Discharge through the grinder housing with 200 mm or 250 mm hole plate diameter.



Maschinenfabrik Seydelmann KG

info@seydelmann.com Tel. +49 (0)711 / 49 00 90-0 Hoelderlinstrasse 9
www.seydelmann.com Fax +49 (0)711 / 49 00 90-90 70174 Stuttgart, Germany

Cutters · Mixers · Grinders
Emulsifiers · Production Lines

Measurements (200 mm)

- H1 = 750 mm / 29.5 in
- H2 = 1200 mm / 47.2 in
- H3 = 2400 mm / 94.5 in
- H4 = 3420 mm / 134.7 in
- L1 = 1550 mm / 61.0 in
- L3 = 3620 mm / 142.5 in
- L4 = 3140 mm / 123.6 in
- L5 = 2500 mm / 98.4 in
- L6 = 3520 mm / 138.6 in

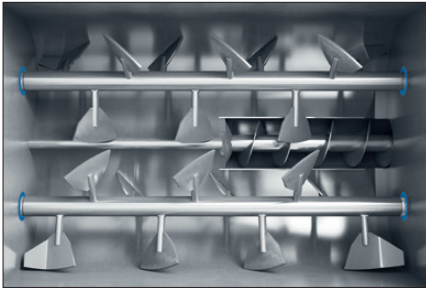
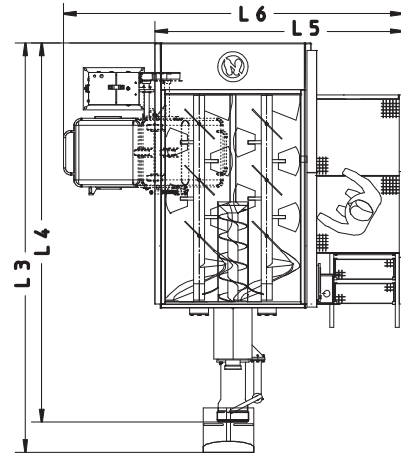
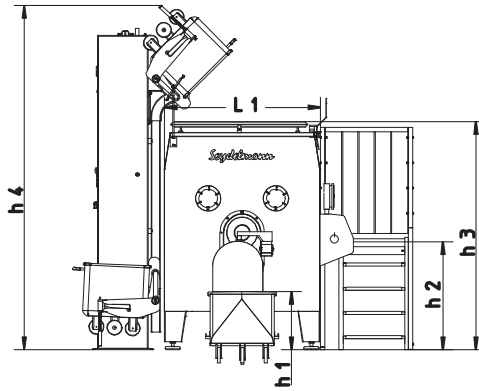

Top view: Hopper



Bayonet locking

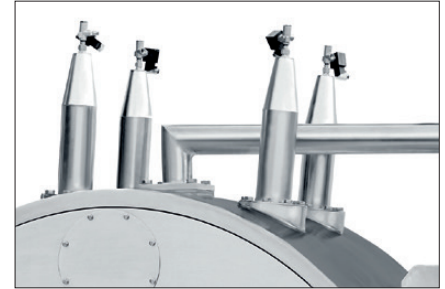

Hydraulic hopper lid with snow horns (optional)

Standard equipment

- Two mixing shafts with mixing paddles
- Forwards and backwards running mixing shafts
- Feeding and working worm
- Short worm housing for 2-pieces Enterprise cutting set or standard worm housing for cutting set 5-pieces
- Double side walls
- Thermal overload control
- Bayonet locking
- Outlet protection device
- Embedded covers
- Working platform
- Control panel with pressure & rotary switch
- Separate electrical cabinet, stainless steel

Additional equipment

- Stepless frequency-controlled drive of the working worm
- Stepless frequency-controlled drives of the mixing shafts
- Cooling and/or cooking function
- Indirect cooling/heating via Pillow Plates
- CIP cleaning (Cleaning in Place) and/or SIP cleaning (Sterilize in Place)
- Loading via vertical loading device or loading device for large containers
- Separating set
- Pneumatic separating device
- Two-stage separating set
- Outside knife
- Hydraulic hopper lid
- Additional hopper safety frame
- Anti-block unit
- Holding device
- Weighing unit
- Outlet tube
- Fat analysis
- Water-/liquid nozzle
- Swivel mounted control panel
- Worm cradle
- Two-hand operation

Auto Command Touch 2000

- Digital display for gear, speed, running time, temperature, time
- Switch-off automatic system for temperature and running time
- Service and maintenance indication
- Touch Display protected against dust and water
- Upgrade to 3000 and 4000 possible



Auto Command Touch 4000 (optional)

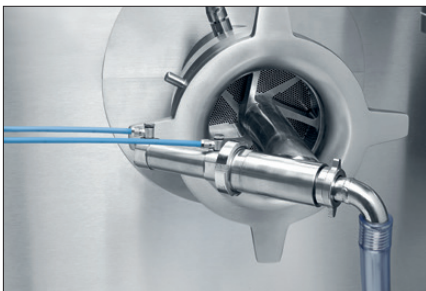

Pneumatic separating device (optional)



Pillow Plates (optional)

Maschinenfabrik Seydelmann KG

info@seydelmann.com Tel. +49 (0)711 / 49 00 90-0 Hoelderlinstrasse 9
 www.seydelmann.com Fax +49 (0)711 / 49 00 90-90 70174 Stuttgart, Germany

**Cutters · Mixers · Grinders
 Emulsifiers · Production Lines**